

INFINITE RANGE - CENTRE ACCESS CURVED DOOR

CURVED SLIDING ENCLOSURE CENTRE ACCESS FOR CORNER APPLICATION

Please read these instructions before installing, as incorrect fitting will invalidate the guarantee-carry out each stage before moving onto the next.

If you are unsure about these instructions please contact Kudos Shower Products:

Customer Service Helpline: 01539 564040

IMPORTANT SAFETY NOTICE

The glass supplied with this enclosure is toughened safety glass in accordance with British Safety Standards. Care should be exercised when handling the glass to avoid knocking or bumping the glass, particularly the edges and corners of the glass as this could cause the glass to shatter into small fragments. It is essential to protect the glass by resting it on a soft protective surface during installation such as cardboard or carpeting.

KEY STAGES TO INSTALLATION

- 1 Check package contents
- 2 Install wall frames vertical and plumb.
- 3 Fit fixed glass side panels
- 4 Fit Head and Bottom rails
- 5 Adjust, plumb, level then tighten clamps
- 6 Fit door glass onto hinges
- 7 Fit the handle
- 8 Fit the door seals
- 9 Fit wall profile covers
- 10 Fit seals between glass and wall profiles
- 11 Remove protective film from wall profile covers
- 12 Silicone seal the unit

TOOLS REQUIRED

- Flat-headed screwdriver - medium
- Pozi-drive screwdriver - medium
- Spirit level
- Tape measure
- Silicone sealant - clear
- Electric drill
- 7mm masonry drill
- 4mm & 2.5mm allen keys (supplied)
- Scissors
- Pencil
- Screw wizard tool (supplied)

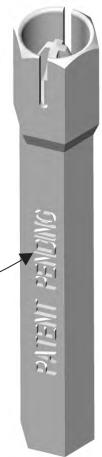

Use this useful screw wizard tool to insert screws through wall profiles into wall and start first one or two turns then use your conventional screw driver.

IMPORTANT

- Check appearance of shower enclosure. Any defects must be reported to Kudos Shower Products before assembly / installation.
- Claims for imperfections will only be accepted prior to assembly / installation
- Ensure shower tray is level in all directions
- Prior to installation, any gap or crevice between the rim of the tray and wall must be filled with silicone sealant flush with the rim of the tray - see detail opp.
- Waterproof walls using ceramic tiles/shower panels etc., before installation.
- Check the enclosure adjustment sizes are suitable for your installation
- Use care when drilling into walls to avoid hidden pipes or electrical cables

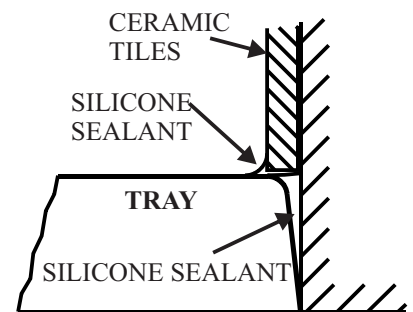

CLEANING

GENERAL- use only warm soapy water and damp cloth/sponge on a regular basis.

Do not use abrasive scouring powders, chemicals or aerosol cleaners- these may result in damage to the surfaces, in particular, the chrome plated component parts

THESE INSTRUCTIONS ARE TO BE LEFT WITH THE USER

1 CONTENTS, carefully check contents. It is advisable to keep contents in protective packing until required.

2 FITTING THE WALL FRAMES, Each wall frame is screwed to the wall with 3 No8x30 screws and wall plugs (provided). Position one wall frame on tray 15mm from front face of tray (see Fig.1). Using a spirit level ensure it is vertical (not leaning in or out of the opening). Mark the position of the 3 wall through the wall frame. Remove wall frame & drill

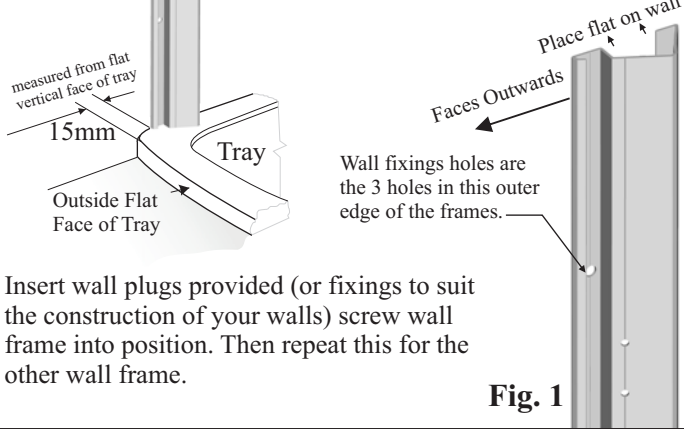

Insert wall plugs provided (or fixings to suit the construction of your walls) screw wall frame into position. Then repeat this for the other wall frame.

Fig. 1

3 BEFORE INSTALLING WALL PROFILES: Because it will be difficult to access after the door is installed, it is necessary to clip on the OUTSIDE wall profile covers BEFORE installing the wall profiles. Carefully remove two wall profile covers from the protective packing but DO NOT remove the protective film from the surface of the covers at this time. Clip on the covers to the faces of the wall profiles that will be on the outside of the unit as per the illustration in Fig. 2 and Fig. 3 below. **EXERCISE CARE WHEN HANDLING THESE COVERS TO AVOID DAMAGE.**

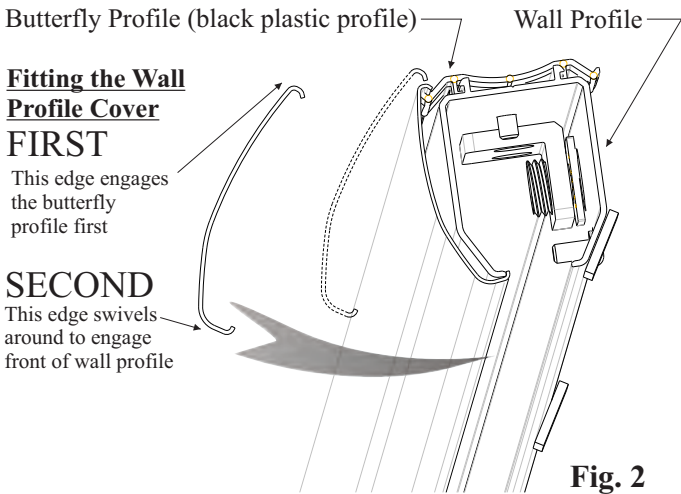

Fitting the Wall Profile Cover

FIRST

This edge engages the butterfly profile first

SECOND

This edge swivels around to engage front of wall profile

Fig. 2

FIT WALL PROFILE COVERS TO OUTSIDE ONLY AT THIS STAGE

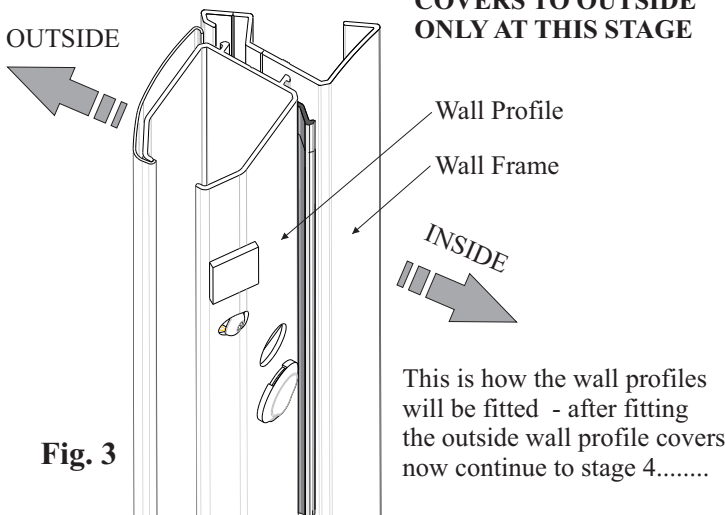
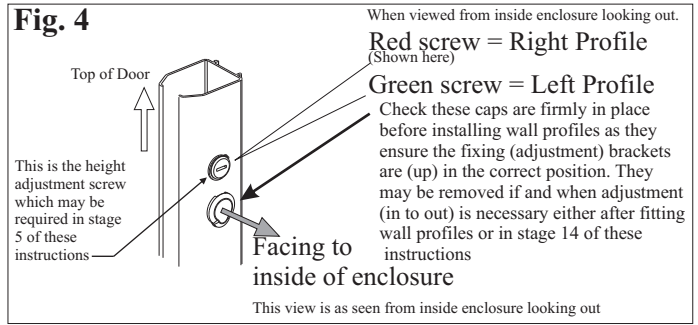

Fig. 3

This is how the wall profiles will be fitted - after fitting the outside wall profile covers now continue to stage 4.....

4 FITTING THE WALL PROFILES, Looking outward from inside of the enclosure, the left wall profile is identified by the green screw which should face the inside of the enclosure and be nearest to the top. Similarly the right wall profile shown here in Fig.4 is the one with the red screw which should face the inside of the enclosure and be nearest to the top.



When viewed from inside enclosure looking out. Red screw = Right Profile (Shown here) Green screw = Left Profile Check these caps are firmly in place before installing wall profiles as they ensure the fixing (adjustment) brackets are (up) in the correct position. They may be removed if and when adjustment (in to out) is necessary either after fitting wall profiles or in stage 14 of these instructions

This view is as seen from inside enclosure looking out

Each wall profile is screwed to the wall frame with 5xNo.8x16 screws (supplied). Position one wall profile on tray and align over the wall frame (see Fig.5). Fix two top screws and then two bottom screws. Next insert the centre screw into the round collar supplied with the screws and then insert this through the rectangular hole in the back of the wall profile and screw into hole in the wall frame.

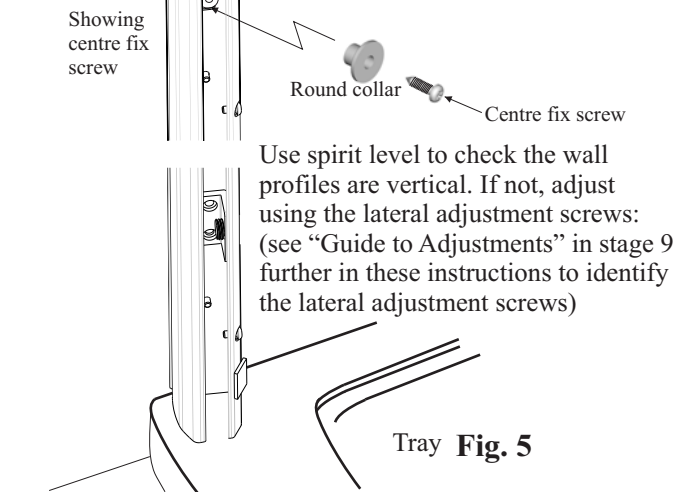

Tray Fig. 5

Use spirit level to check the wall profiles are vertical. If not, adjust using the lateral adjustment screws: (see "Guide to Adjustments" in stage 9 further in these instructions to identify the lateral adjustment screws)

5 PREPARING THE RAILS, The bottom rail has nylon height adjustment screws pre-fitted. These are the black nylon hexagonal headed screws that may be adjusted, if necessary, later on to ensure the rail is fully supported onto the tray.

Remove the m4-csk screws from the inside face of both rails at the ends (2 screws at each end) this is where the glass will be clamped see Fig.6 and keep these ready for use later on.

Only remove these 2 screws at end of each rail

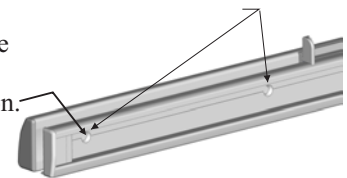

Fig. 6

The top rail does not have the height adjustment screws.

If the height adjustment in stage 8 of these instructions, creates a gap under the bottom rail - this is the spanner (supplied) that you will use to adjust "rail support screws" down until they seat onto the tray for the rail to be fully supported on the tray.

spanner supplied



These are the black nylon hex. head screws which may require to be adjusted down onto tray later on.

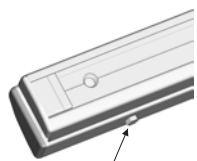

Fig. 7

6 FITTING GLASS PANELS, The fixed panels can now be fitted. Each panel is pre-fitted with a bottom gasket as shown in Fig. 8 below. Ensure when fitting these panels that the soft seal is facing inwards into the shower.

The edge of the glass with the seal flush to corner of glass will be fitted into the wall profile

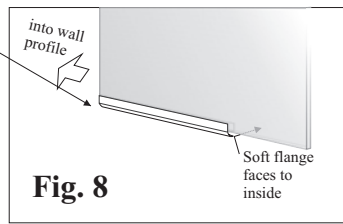

Fig. 8

Step A:
Lay bottom rail onto tray approximately in the centre and 15mm back from vertical flat front face of tray.

Step B:
Slide the fixed panel into the glass clamps in the wall profile keeping the bottom edge of the panel just above the rail.

Step C:
Slide panel down into the recess in the bottom rail. Make sure glass is pushed up to and touching the clear plastic part in the bottom rail. The bottom seal must rest on the tray with the soft flange facing inwards.

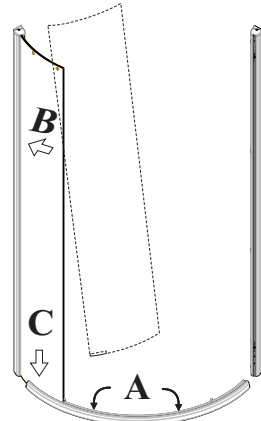

Fig. 9

Glass must be pushed up against this clear plastic part

Step D:
Now replace the two m4 csk screws which were removed in stage 5 (see Fig.6) of these instructions, into the holes as shown here and tighten using 2.5mm allen key (supplied) to clamp glass to rail.

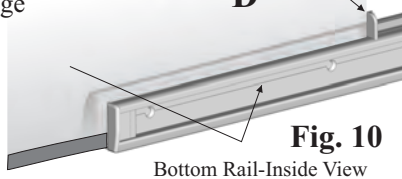

Fig. 10

Bottom Rail-Inside View

Step E:
Now repeat this procedure to fit the other fixed panel on the opposite side.

Soft flanges rest on tray
face inside

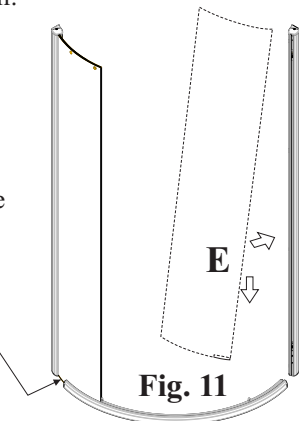

Fig. 11

Step F:
Now position the top rail onto the two glass panels ensuring the glass is fully inserted into the rail. Push each glass panel against the clear plastic part as before. Insert the remaining m4 csk screws into the holes at each end of the rail and tighten

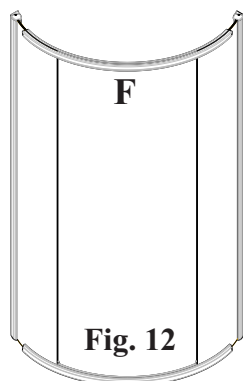

Fig. 12

7 The two glass panels and the top and bottom rails now form a rigid unit that can be moved to the left or right. Ensure the unit is correctly positioned so that the gap between the end of the rails and the wall profiles is the same on both sides.

Slide glass panels and top and bottom rails as one unit to left or right to set gaps equally.

Place spirit level onto edge of each glass panel to check for vertical. If necessary push on glass to set in vertical position.

Now tighten the glass clamps in the wall profiles using the 2.5mm allen key provided. To identify the glass clamps in the wall profile see Fig. 14 The design makes it impossible to break the glass by over tightening because the screw heads will tighten against the wall profiles first. So do ensure these are fully tight

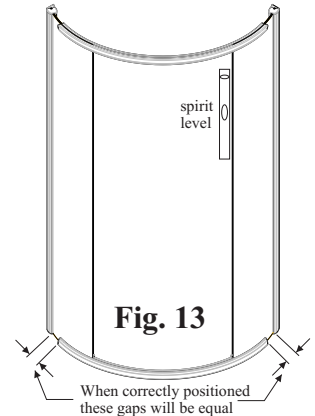

Fig. 13

When correctly positioned these gaps will be equal

8 LEVELLING THE UNIT, Place a spirit level onto the bottom rail and check if this is level. If not, use the height adjustment screws to level the unit by raising the relevant side. See the "Guide to Adjustments" below in stage 9. If it has been necessary to adjust the height to level the unit, the rail support screws may need to be adjusted downwards until the rail is fully supported on the tray - see Fig.7 in stage 5 of these instructions.

9 Guide to adjustments
shown on inner face of wall profile

The unit is designed to enable 3 dimensional adjustment during installation without removing any part of the unit already installed. The diagram here illustrates the adjustments possible and their location.

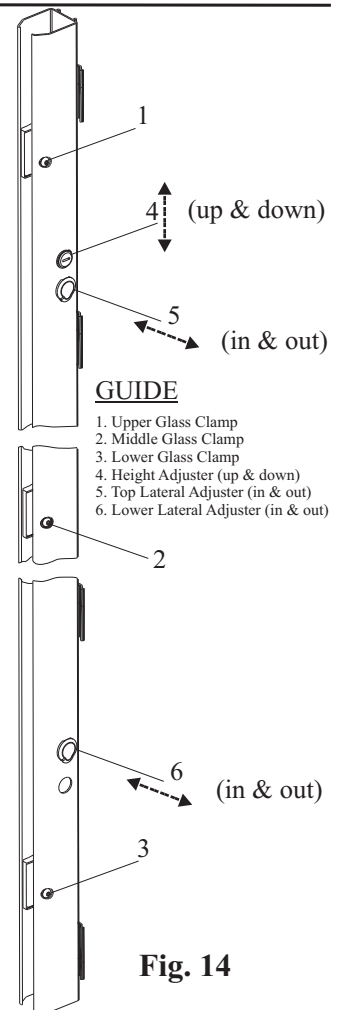

GUIDE

1. Upper Glass Clamp
2. Middle Glass Clamp
3. Lower Glass Clamp
4. Height Adjuster (up & down)
5. Top Lateral Adjuster (in & out)
6. Lower Lateral Adjuster (in & out)

Fig. 14

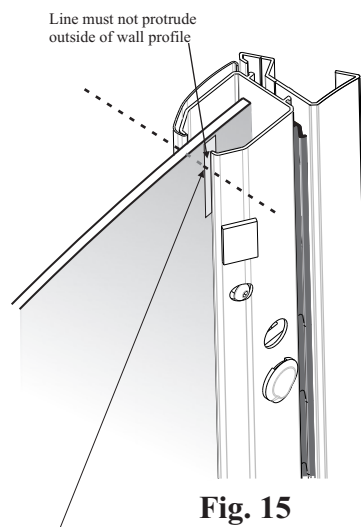

Fig. 15

Line markings on glass at top and bottom must not protrude outside of wall profile after adjusting panels as this will result in clamps not gripping the glass fully

10 FITTING THE SLIDING DOORS, Each sliding door has four wheels pre-fitted. In order to insert the top wheels into the top track as shown in Fig. 16 - it will be necessary to loosen the four bottom wheels. Each door can then be angled as shown and the two top wheels inserted into the track, then lower the door into position by guiding the two bottom wheels into the bottom track.

CHECK if the doors are hanging vertical to the fixed side panels by comparing the glass edges. Also carefully bring the two doors towards the central closed position (DO NOT BUMP THE GLASS DOORS INTO EACH OTHER) to see they are parallel on the vertical closing edges. If not, the doors can be adjusted by loosening one or both of the top wheels and moving door glass into correct position, then while holding the glass re-tighten the top wheels. Check again if doors are now hanging correctly then re-tighten the bottom wheels, ensuring they are pushed upward in the bottom track. This will prevent the door from “jumping” out of the track.

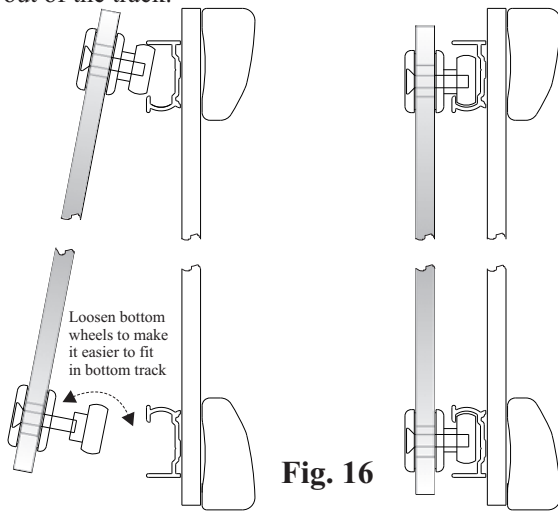

Fig. 16

THIS IMAGE IS SHORTENED IN HEIGHT FOR CLARITY

11 FITTING THE HANDLES, Remove the handles from the packaging and remove the top and bottom screws. Fit to glass in accordance with the detail Fig.17 - Ensure handles are vertical then tighten screws through glass and push in screw covers.

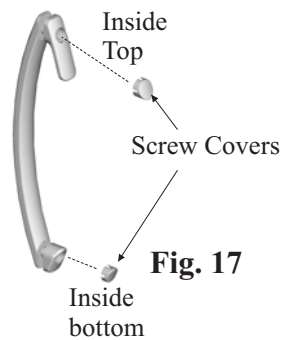

Fig. 17

12 FITTING WEDGE GASKETS, Insert the seals as shown below, Fig.18 - into the recess between the glass and the bottom rail at the ends of the fixed panels where they are clamped into the rail.

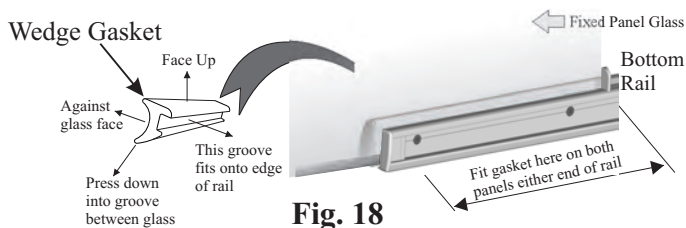

Fig. 18

Press wedge gasket seal down until it seats firmly into the recess and locates aluminium bottom rail into the groove as indicated. If difficult to fit, wet the seal and glass with a little water.

13 FITTING THE DOOR SEALS, Fit the seals shown in Fig. 21. On the overlap sides the long notched seal fits onto the sliding door glass and the shorter seal fits to the fixed panel as shown in Fig. 19, ensure gasket on the fixed panel is pushed firmly down onto the clear plastic part in the bottom rail. Fit the seals to the doors as in Fig. 20.

To make it easier to fit, run a wet cloth down the edge of the glass to which the seal is to be fitted.

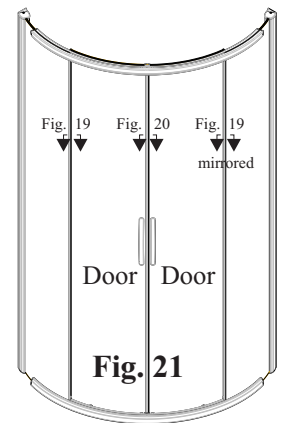

Fig. 21

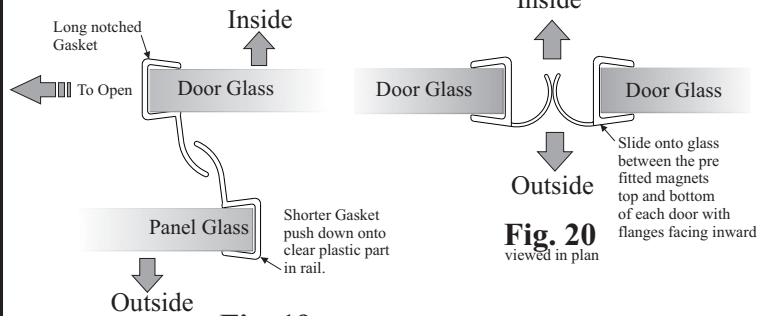

Fig. 19

14 FINAL CHECK AND ADJUSTMENT, Open and close the sliding door and check that it runs smoothly. If not, check that the frame is vertical (in to out) and not twisted. If necessary the frame can be adjusted using the lateral adjustment screws see Fig. 14 in guide to adjustments stage 9

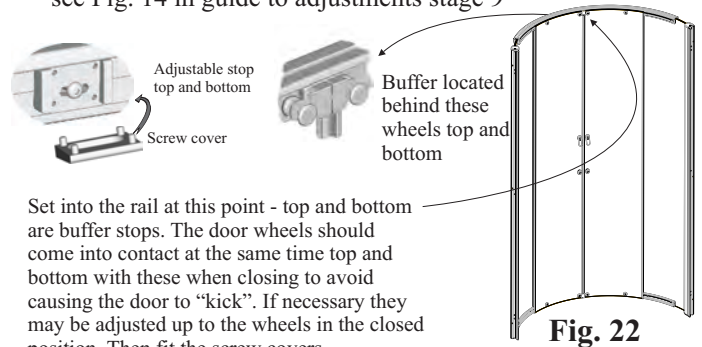

Fig. 22

Set into the rail at this point - top and bottom are buffer stops. The door wheels should come into contact at the same time top and bottom with these when closing to avoid causing the door to “kick”. If necessary they may be adjusted up to the wheels in the closed position. Then fit the screw covers.

15 FITTING THE WALL PROFILE COVERS Care should be used when handling these covers, before they are fitted to the wall profiles.

Ensure nylon butterfly brackets are correctly spaced by sliding the top one as far up as it will easily go and the lower one as far down as it will easily go. The other two should be spaced equally between the top and bottom. Engage the back edge of the wall profile cover over all four butterfly brackets and then swivel the cover around to engage over the front of the wall profile and clip into position. NOTE The “flatter” edge of the covers are towards the door opening and the tighter rolled edge engages the butterfly brackets.

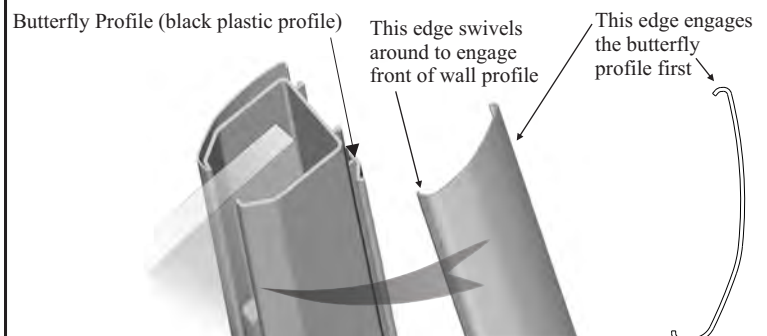

Fig. 23

16 FITTING THE GLASS PANEL SEALS.

FIRST Remove the plastic protective film from the wall profile covers at this time by peeling it away.

NEXT Fit the glass seals at junction of glass and wall profiles. Fit glass edge seals to both inner and outer faces of two fixed panels at junction of wall profiles and glass

NOTE: different seals on each side.

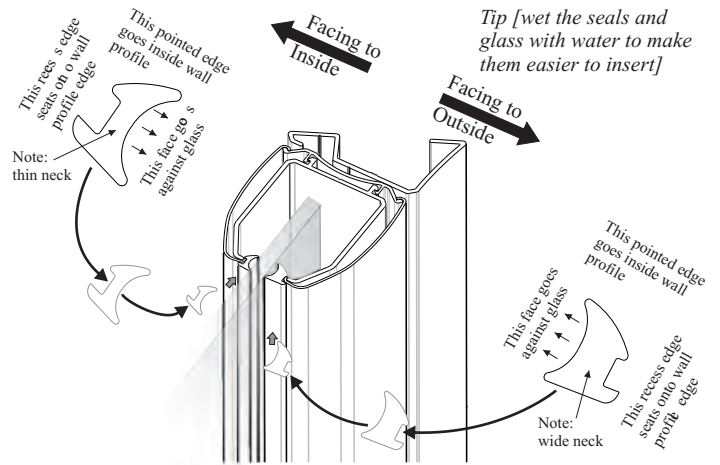

Fig. 24

17 FIT THE TWO TOP CAPS to the wall profiles using the No.6 x 12 screws supplied.

FINALLY SEAL THE ENCLOSURE, Using a clear silicone sealant apply a thin bead to all the edges as shown. To achieve a neat finish it is recommended that each joint to be sealed is masked either side of the joint so that only a maximum of 3mm either side of the joint is exposed. The masking tape should then be removed immediately after sealing (DO NOT allow silicone to dry over masking tape).

DO NOT USE OR DISTURB THE ENCLOSURE FOR 24 HOURS AFTER SEALING TO ALLOW THE SILICONE TO DRY.

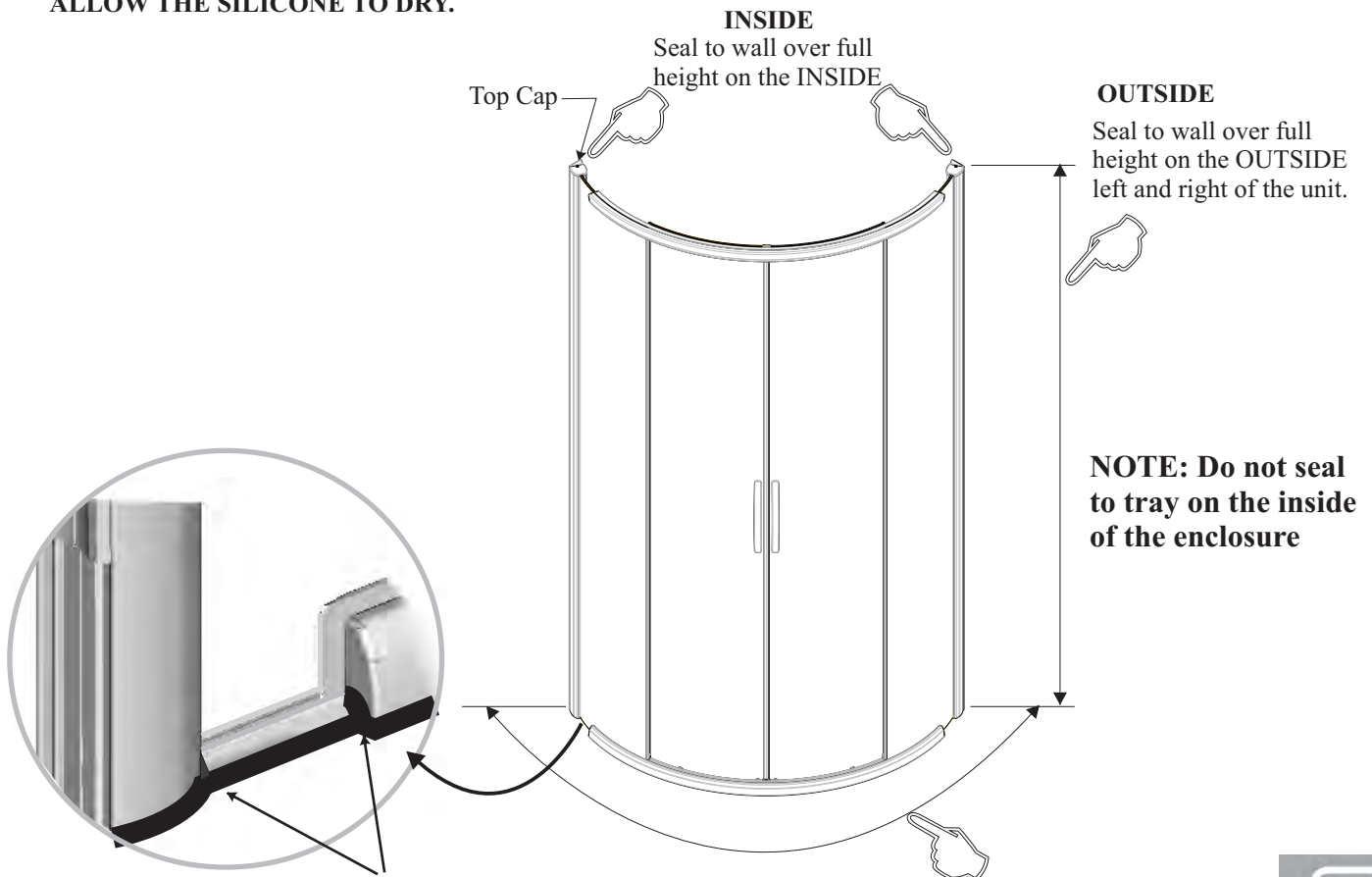
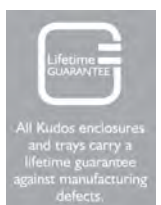

Fig 25

Run the sealant up both sides of the gaskets where they meet the wall profiles and bottom rail - do this on both fixed panels to the left and right of the door on the OUTSIDE only



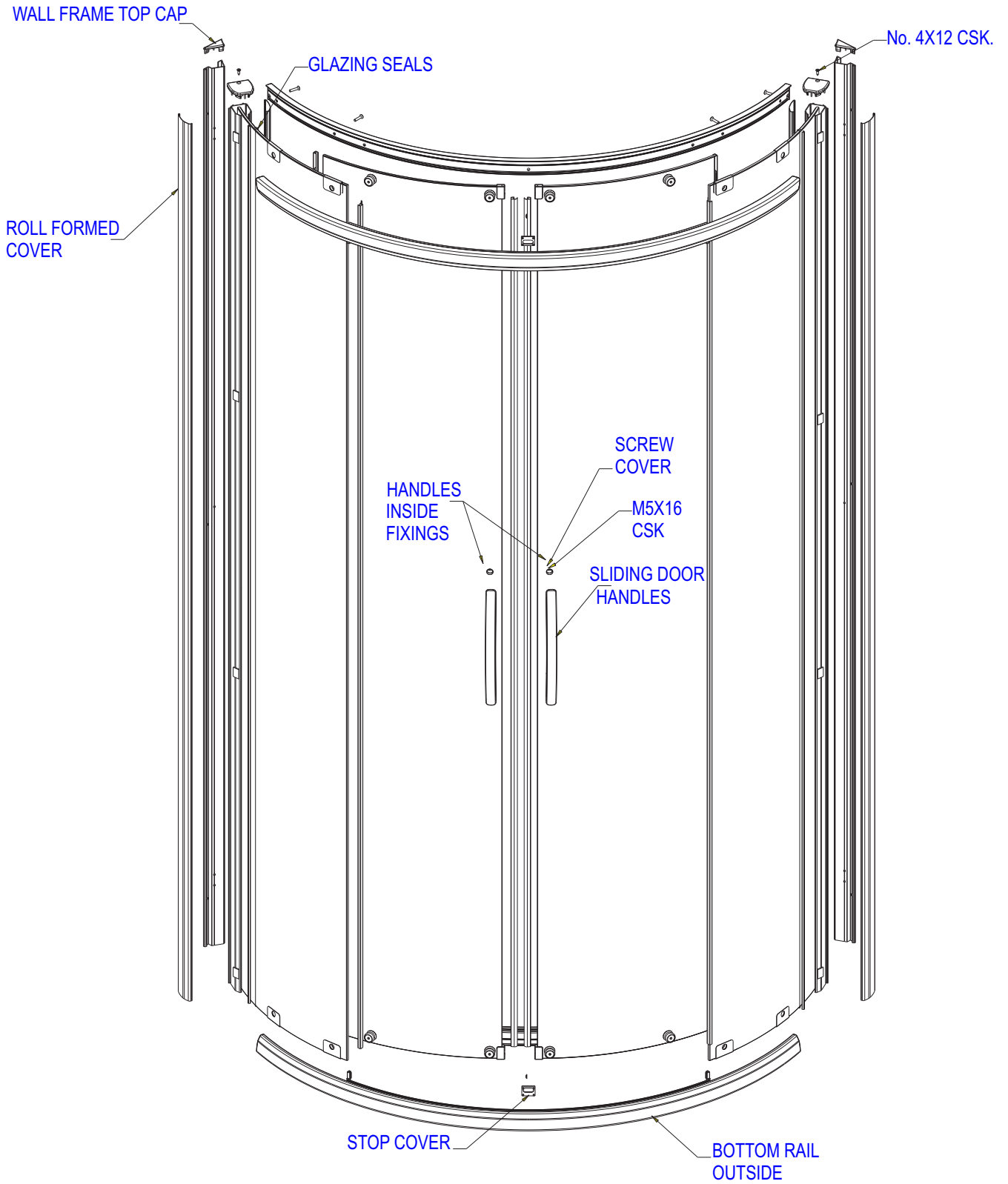

Fig 26
 CONTENTS OF PACKAGE