

INFINITE RANGE - SIDE ACCESS SLIDER



SIDE ACCESS SLIDING DOOR FOR CORNER APPLICATION

Please read these instructions before installing, as incorrect fitting will invalidate the guarantee-carry out each stage before moving onto the next. There are three sets of instructions enclosed in this pack. Select the set to suit your configuration.

1. Side Access Slider Door Only (Recess)
2. Side Access Slider Door + 1 Side Panel (Corner)
3. Side Access Slider Door +2 Side Panels (Peninsula)

If you are unsure about these instructions please contact Kudos Shower Products:

Customer Service Helpline: 01539 564040

IMPORTANT SAFETY NOTICE

The glass supplied with this enclosure is toughened safety glass in accordance with British Safety Standards. Care should be exercised when handling the glass to avoid knocking or bumping the glass, particularly the edges and corners of the glass as this could cause the glass to shatter into small fragments. It is essential to protect the glass by resting it on a soft protective surface during installation such as cardboard or carpeting.

KEY STAGES TO INSTALLATION

- 1 Check package contents
- 2 Install wall frames vertical and plumb.
- 3 Fit fixed glass side panels
- 4 Fit Head and Bottom rails
- 5 Adjust, plumb, level then tighten clamps
- 6 Fit door glass onto hinges
- 7 Fit the handle
- 8 Fit the door seals
- 9 Fit wall profile covers
- 10 Fit seals between glass and wall profiles
- 11 Remove protective film from wall profile covers
- 12 Silicone seal the unit

TOOLS REQUIRED

- Flat-headed screwdriver - medium
- Pozi-drive screwdriver - medium
- Spirit level
- Tape measure
- Silicone sealant - clear
- Electric drill
- 7mm masonry drill
- 4mm & 2.5mm allen keys (supplied)
- Scissors
- Pencil
- Screw wizard tool (supplied)



Use this useful screw wizard tool to insert screws through wall profiles into wall and start first one or two turns then use your conventional screw driver.

IMPORTANT

- Check appearance of shower enclosure. Any defects must be reported to Kudos Shower Products before assembly / installation.
- Claims for imperfections will only be accepted prior to assembly / installation
- Ensure shower tray is level in all directions
- Prior to installation, any gap or crevice between the rim of the tray and wall must be filled with silicone sealant flush with the rim of the tray - see detail opp.
- Waterproof walls using ceramic tiles/shower panels etc., before installation.
- Check the enclosure adjustment sizes are suitable for your installation
- Use care when drilling into walls to avoid hidden pipes or electrical cables

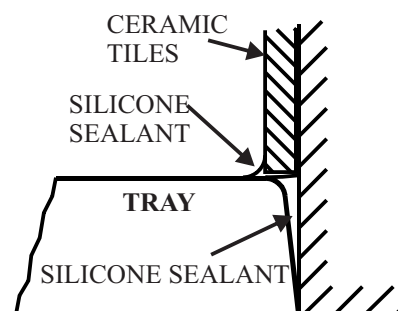

CLEANING

GENERAL- use only warm soapy water and damp cloth/sponge on a regular basis.

Do not use abrasive scouring powders, chemicals or aerosol cleaners- these may result in damage to the surfaces, in particular, the chrome plated component parts

THESE INSTRUCTIONS ARE TO BE LEFT WITH THE USER

1 CONTENTS, carefully check contents. It is advisable to keep contents in protective packing until required.

2 The door can be installed with the closing side to either the left or the right. The side panel is common to either configuration and the following options are achievable with the door and one side panel. Decide at this stage which suits your need.

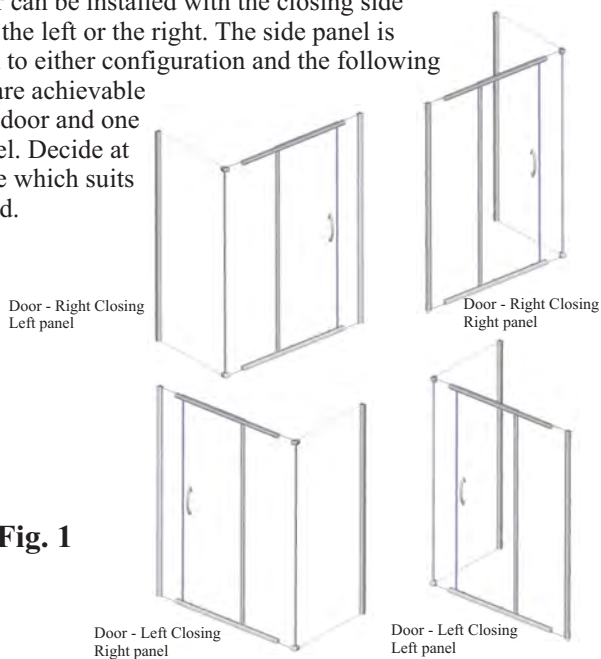
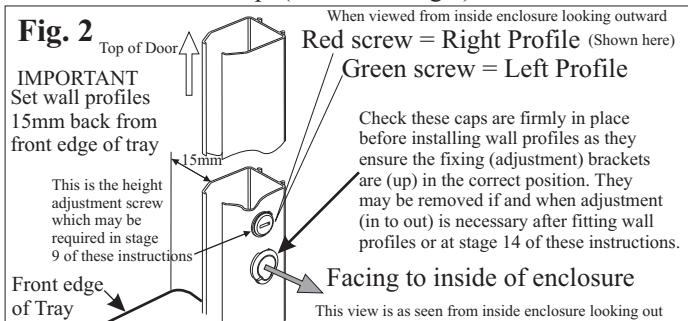

Fig. 1

THE DOOR CAN BE INSTALLED WITH THE CLOSING SIDE EITHER LEFT OR RIGHT. THE FOLLOWING SEQUENCE SHOWS A LEFT HAND CLOSING DOOR (with left hand side panel) SEE ILLUSTRATION ON BACK PAGE FIG. 23 FOR A RIGHT CLOSING DOOR.

3 FITTING THE WALL PROFILES, When looking outward from inside of the enclosure, the left wall profile is identified by the green screw which should face the inside of the enclosure and be nearest to the top. Similarly the right wall frame is the one with the red screw which should face the inside of the enclosure and be nearest to the top. (See below Fig.2)



Each wall profile is screwed to the wall with 4 No8x30 screws and wall plugs (provided). Position one wall profile on tray 15mm from front face of tray (see Fig.3) and using a spirit level ensure it is vertical (not leaning backwards or forwards in the opening). Mark the position of the 4 holes on the wall wall profile. Remove wall profile and drill holes 7mm masonry drill bit.

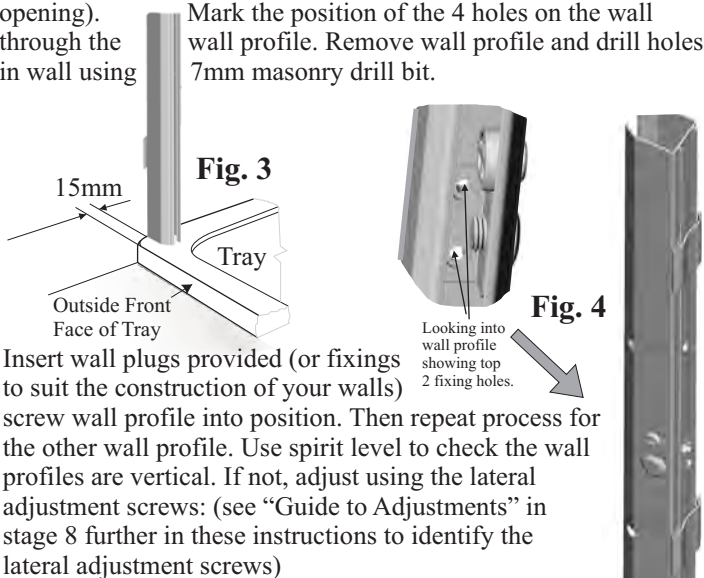

Insert wall plugs provided (or fixings to suit the construction of your walls) screw wall profile into position. Then repeat process for the other wall profile. Use spirit level to check the wall profiles are vertical. If not, adjust using the lateral adjustment screws: (see "Guide to Adjustments" in stage 8 further in these instructions to identify the lateral adjustment screws)

4 FITTING GLASS PANELS, 4.1 On the large glass side panel there is a corner seal into which one of the door side panels will be inserted to form the corner. Using the detail in Figs. 5 & 6 determine the bottom of the large side panel and fit the bottom seal as shown.

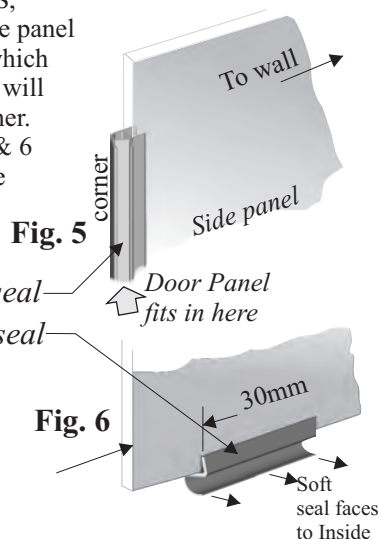

This is the corner seal
This is the bottom seal

This is the seal for the bottom of the side panel. The soft edge must be to the inside of the enclosure and be set 30mm from the corner when fitting gasket.

Fit the corner bracket by sliding it onto the outer bottom corner of the large side panel (Fig. 7) until the edge of the corner seal lines up with the bracket as shown below in Fig.8. Tighten grub screw on the inside face with the 3mm allen key supplied.

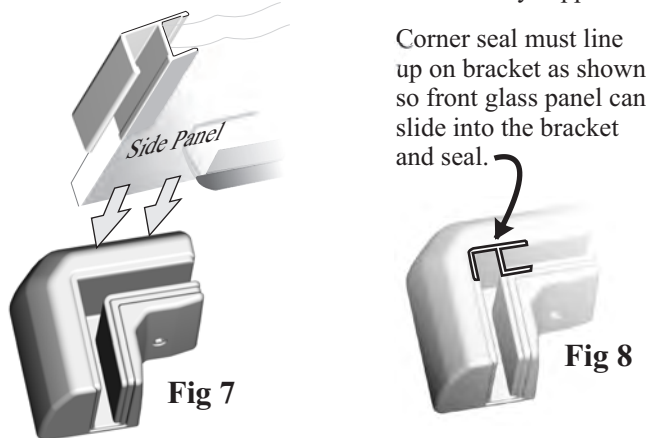

4.2 Insert large side panel into wall profile glass clamps (see Fig.9) with the soft seal onto the tray and the fitted corner bracket to the front. Move the panel in or out until the corner bracket is spaced equal distance from the front edge of the tray as it is from the side face of the tray. Ensure the panel is vertical then fully tighten the 3 glass clamps screws using 2.5mm allen key supplied (see Fig 19). If after adjusting for vertical, the corner bracket is not seated firmly on the tray, loosen grub screws and tap the bracket down onto the tray (caution - do not exceed 5mm adjustment on this bracket) Pack between bracket and tray if you require more adjustment.

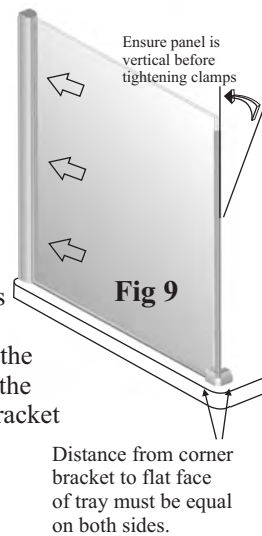

5 PREPARING THE RAILS, The top and bottom rails are identical and both have nylon height adjustment screws pre-fitted. These are the black nylon hexagonal headed screws that may be adjusted, if necessary, later on to ensure the rail is fully supported onto the tray.

Remove the m4-csk screws from the inside face of both rails at the ends (2 screws at one end and 1 screw at opposite end) this is where the glass will be clamped see Fig.10 and keep these ready for use later on.

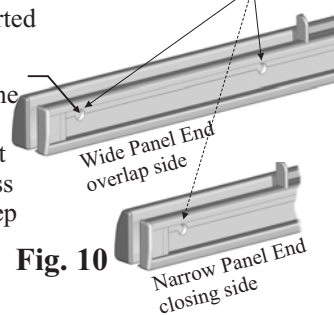

Fig. 10

Now select one of the rails that will be the top rail (both rails are identical at this stage). The top rail does not require the height adjustment screws. These may be removed and discarded and the holes can be plugged with the small caps provided for this purpose. When installing the top rail, these caps will be to the top of the rail and will not be visible - see Fig. 11



If the height adjustment in stage 7 of these instructions, creates a gap under the bottom rail - this is the spanner (supplied) that you will use to adjust "rail support screws" downwards until they seat onto the tray for the rail to be fully supported on the tray.

Fig. 11

6 PREPARING THE FRONT GLASS PANELS: There is a narrow and a wide glass panel. In the pack there are two short gaskets and two longer gaskets. For fixed panels that will be fitted into a wall profile use the longer gasket. For panels that will form a corner (with a side return panel) fit the shorter one. Determine which panel will form a corner (depending on your configuration) with the large side return panel and set the gasket 38mm from the glass edge that will fit into the corner bracket as shown in Fig. 12. For a fixed panel that will not form a corner but fit directly into a wall profile use the longer gasket and set this flush with the glass edge that will fit into the wall profile.

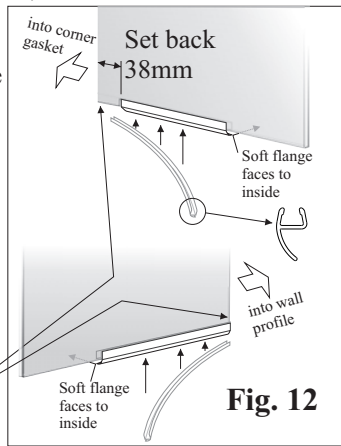

Fig. 12

Wet the seals and the glass edges with water to make insertion easier

Step A:

Lay bottom rail onto tray approximately in the centre and 15mm back from vertical flat front face of tray.

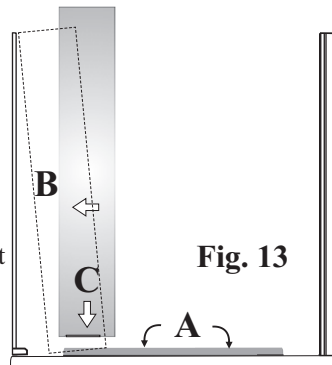

Fig. 13

Step B:

Slide the panel that will form the corner into the corner gasket ensuring glass is flush with top of gasket and press this into the gasket over full height and into bottom corner bracket.

Step C:

Push panel down into the recess in the bottom rail. Make sure glass is pushed up to and touching the clear plastic part in the bottom rail. The bottom seal must rest on the tray with the soft flange facing inwards.

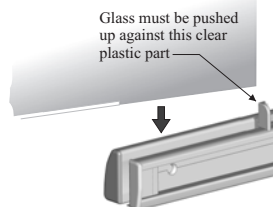

Bottom Rail-Inside View Fig. 14

Step D:

Now replace the m4 csk screw(s) removed earlier in stage 5 (see Fig.10) of these instructions, into the end as shown here and tighten using 2.5mm allen key (supplied) to clamp glass in rail.

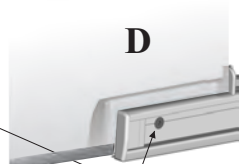

Bottom Rail-Inside View Fig. 15

Step E:

Now fit the top corner bracket over the top corner and press down ensuring glass is fully inserted. Then fit the panel that will be inserted into the wall profile on the overlap side of door. Slide this panel into the wall profile glass clamps and then down into bottom rail as before. Also ensure the glass is pushed up against the clear plastic part. Then replace m4 csk screw(s) as per Step D previously.

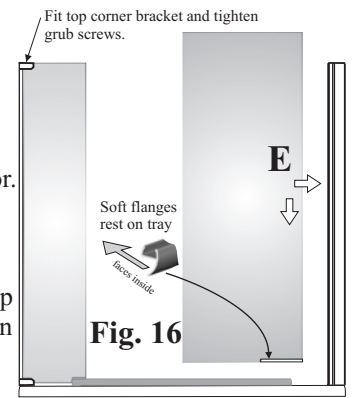

Fig. 16

Step F:

Now position the top rail onto the two glass panels ensuring the glass is fully inserted into the rail. Push each glass panel against the clear plastic part as before. Insert the remaining m4 csk screws into the holes at each end of the rail and tighten.

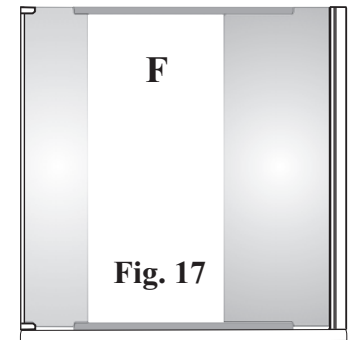

Fig. 17

7 The two glass panels and the top and bottom rails now form a rigid unit that can be moved to the left or right. Ensure the unit is correctly positioned so that the gap between the outside edge of the bottom corner casting is equal distance from the front and side of the tray.

Slide glass panels and top and bottom rails as required to position unit correctly.

Place spirit level onto edge of each glass panel to check for vertical. If necessary push on glass to set in vertical position.

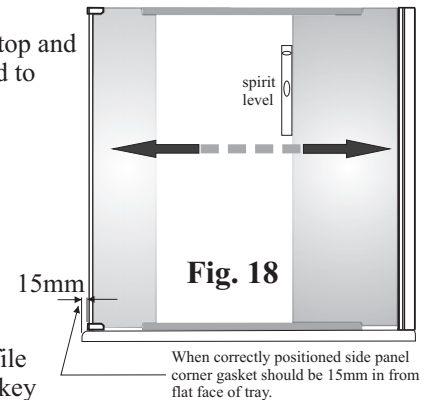

Fig. 18

Now tighten the glass clamps in the wall profile using the 2.5mm allen key provided. To identify the glass clamps in the wall profile see Fig. 19 The design makes it impossible to break the glass by over tightening because the screw heads will tighten against the wall profiles first. So do ensure these are fully tight

8 Guide to adjustments shown on inner face of wall profile

The unit is designed to enable 3 dimensional adjustment during installation without removing any part of the unit already installed. The diagram here illustrates the adjustments possible and their location.

GUIDE

1. Upper Glass Clamp
2. Middle Glass Clamp
3. Lower Glass Clamp
4. Height Adjuster (up & down)
5. Top Lateral Adjuster (in & out)
6. Lower Lateral Adjuster (in & out)

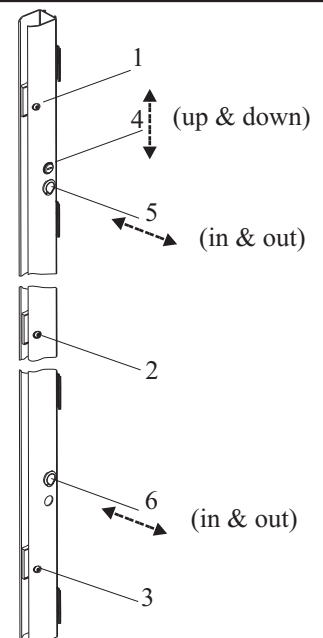

Fig. 19

9 LEVELLING THE UNIT, Place a spirit level onto the bottom rail and check if this is level. If not, use the height adjustment screws to level the unit by raising the relevant side. See the "Guide to Adjustments" in stage 8. If it has been necessary to adjust the height to level the unit, the rail support screws may need to be adjusted downwards until the rail is fully supported on the tray - see Fig.11 in stage 5 of these instructions.

10 FITTING THE SLIDING DOOR, The sliding door has the four wheels pre-fitted. In order to insert the top wheels into the top track as shown in Fig. 20 - it will be necessary to loosen the two bottom wheels. The door can then be angled as shown and the two top wheels inserted into the track, then lower the door into position by guiding the two bottom wheels into the bottom track.

CHECK if the door is hanging vertical to the fixed side panels by comparing the glass edges to see they are parallel on the vertical edges. If not, the door can be adjusted by loosening one or both of the top wheels and moving door glass into correct position, then while holding the glass re-tighten the top wheels. Check again if door is now hanging correctly then re-tighten the bottom wheels, ensuring they are pushed upward in the bottom track. This will prevent the door from "jumping" out of the track inadvertently.

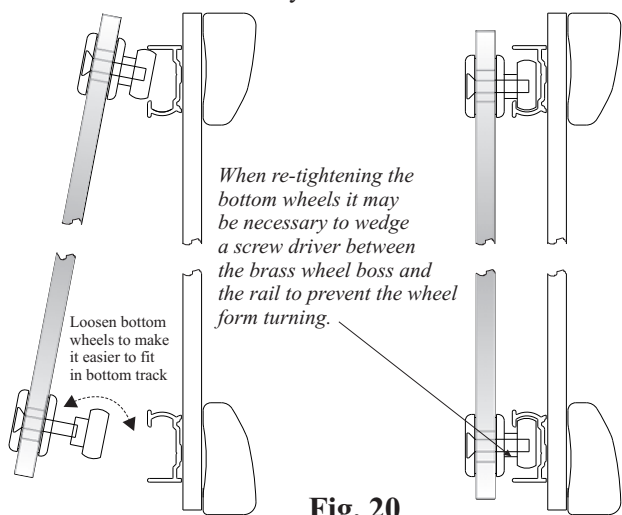

Fig. 20

THIS IMAGE IS SHORTENED IN HEIGHT FOR CLARITY

11 FITTING THE HANDLE, Remove the handle from the packaging and remove the top and bottom screws. Fit to glass in accordance with the detail below, Fig.21 - Ensure handle is vertical then tighten screws through glass and push in screw covers.

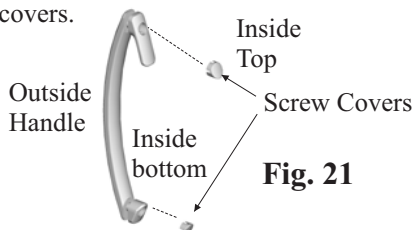

Fig. 21

12 FITTING WEDGE GASKETS, Insert the seals as shown below, Fig.22 - into the recess between the glass and the bottom rail at the ends of the fixed panels where they are clamped into the rail.

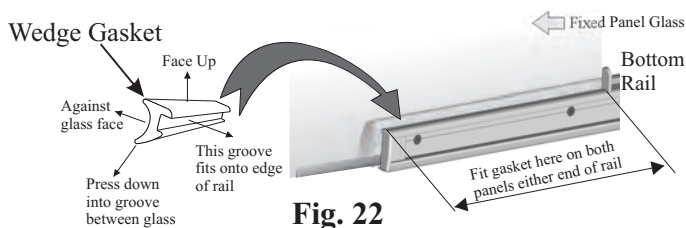
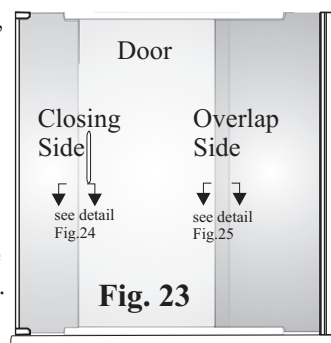

Fig. 22

Press wedge gasket seal down until it seats firmly into the recess and locates aluminium bottom rail into the groove as indicated. If difficult to fit, wet the seal and glass with water.

13 FITTING THE DOOR SEALS, Fit the seals shown in Fig. 25 to the overlap side. The long notched seal fits onto the sliding door glass and the shorter seal fits to the fixed panel as shown. Ensure shorter gasket is pushed firmly down onto the clear plastic part in the bottom rail. Fit gasket as in Fig. 24 to closing side fixed panel.



To make it easier to fit, run a wet cloth down the edge of the glass to which the seal is to be fitted.

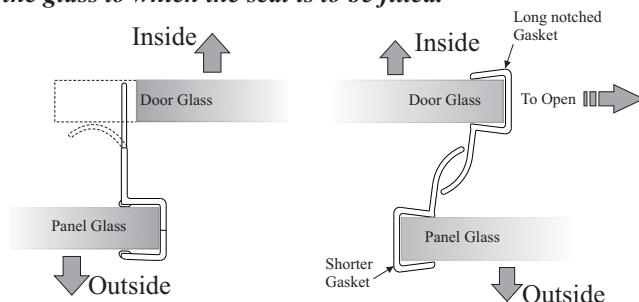

CLOSING SIDE

Fig. 24

viewed in plan

OVERLAP SIDE

Fig. 25

viewed in plan

14 FINAL CHECK AND ADJUSTMENT, Open and close the sliding door and check that it runs smoothly. If not, check that the frame is vertical (in to out) and not twisted. If necessary the frame can be adjusted using the lateral adjustment screws see Fig. 19 in guide to adjustments stage 8

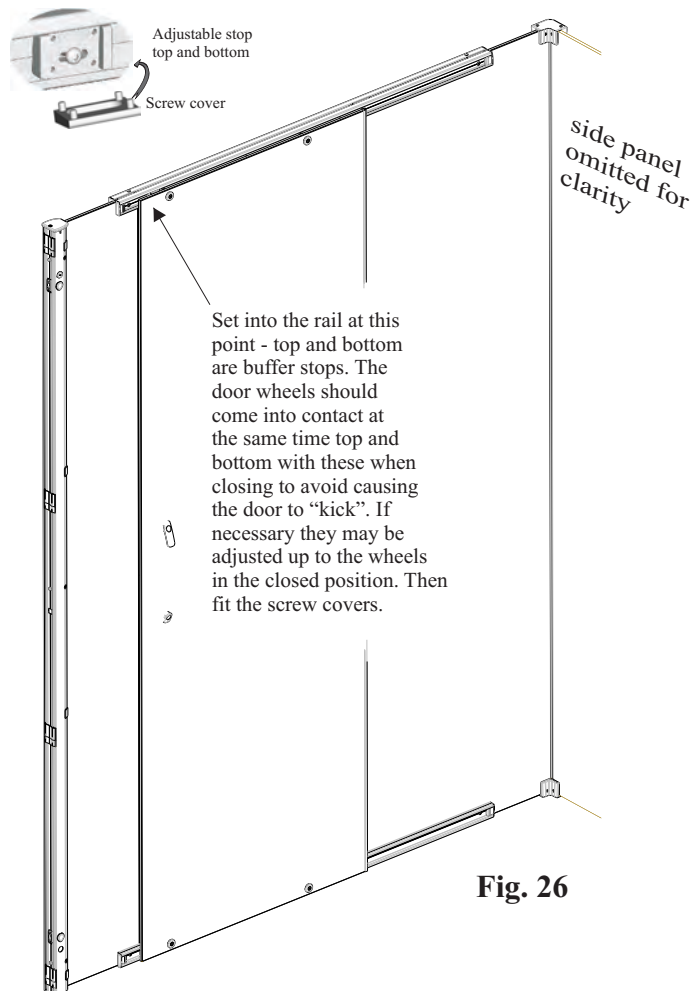

Fig. 26

15 FITTING THE WALL PROFILE COVERS Care should be used when handling these covers, before they are fitted to the wall profiles.

Ensure nylon butterfly brackets are correctly spaced by sliding the top one as far up as it will easily go and the lower one as far down as it will easily go. The other two should be spaced equally between the top and bottom. Engage the back edge of the wall profile cover over all four butterfly brackets and then swivel the cover around to engage over the front of the wall profile and clip into position. **NOTE** The “flatter” edge of the covers are towards the door opening and the tighter rolled edge engages the butterfly brackets.

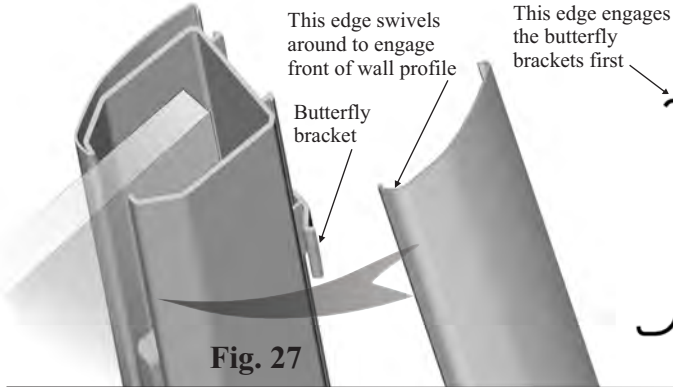

Fig. 27

16 FITTING THE GLASS PANEL SEALS. NEXT Fit the glass seals at junction of glass and wall profiles. Remove the plastic protective film from the wall profile covers at this time by peeling it away.

Fit glass edge seals to both inner and outer faces of two fixed panels at junction of wall profiles and glass

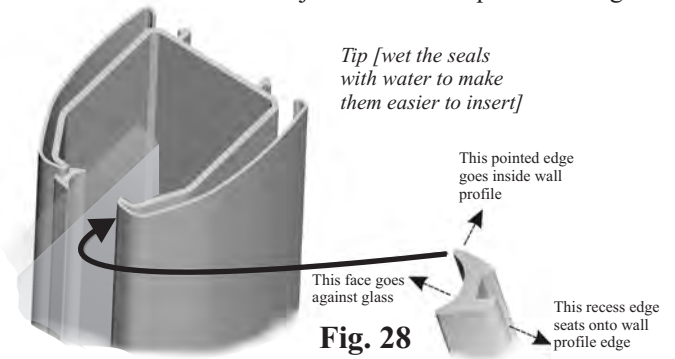

Fig. 28

17 FIT THE TWO TOP CAPS to the wall profiles using the No.6 x 12 screws supplied, and fit top cap to wall frame.

FINALLY SEAL THE ENCLOSURE, Using a clear silicone sealant apply a thin bead to all the edges as shown. To achieve a neat finish it is recommended that each joint to be sealed is masked either side with masking tape so that only a maximum of 3mm either side of the joint is exposed. The masking tape should then be removed immediately after sealing (**DO NOT** allow silicone to dry over masking tape).

DO NOT USE OR DISTURB THE ENCLOSURE FOR 24 HOURS AFTER SEALING TO ALLOW THE SILICONE TO DRY.

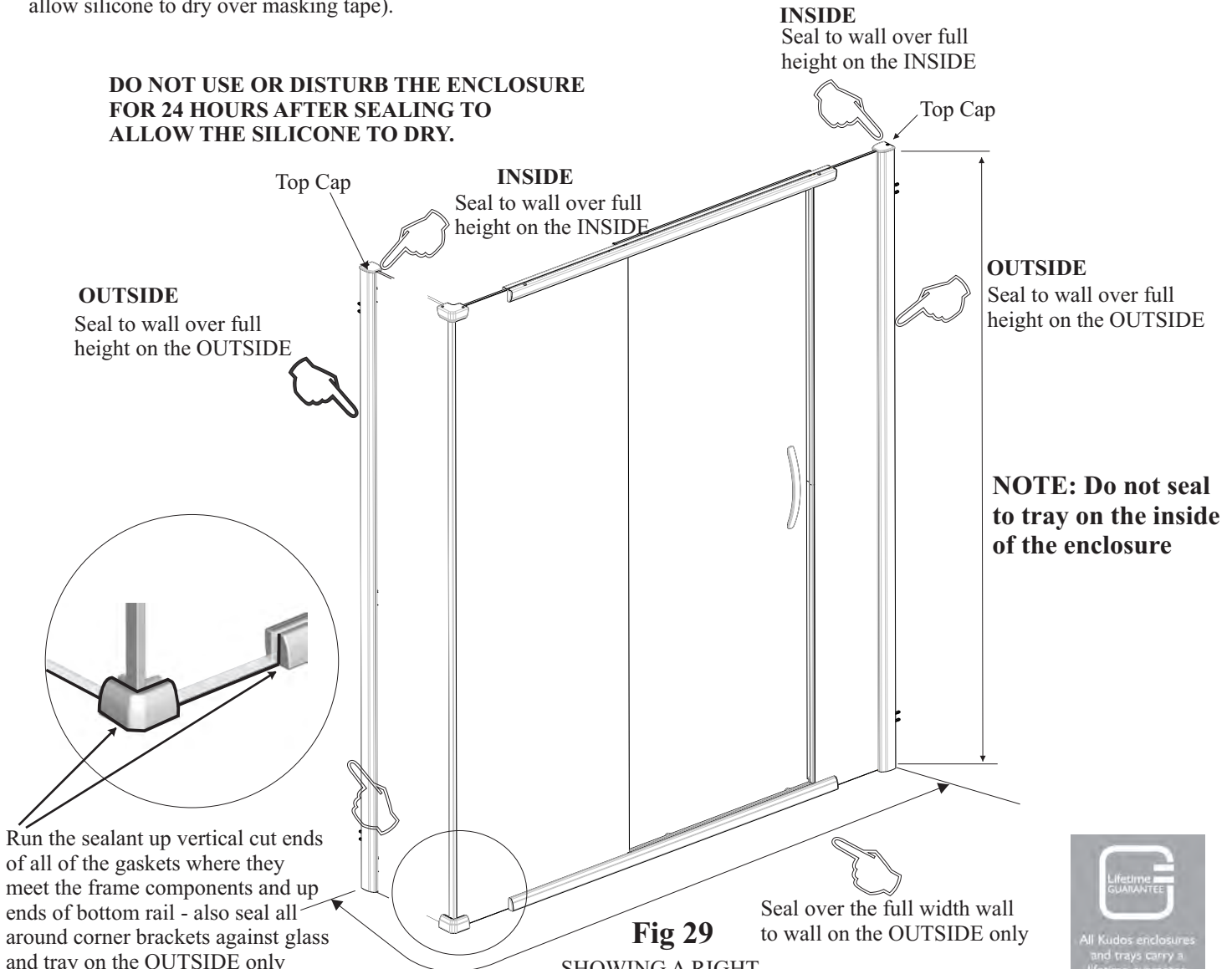

Fig 29

SHOWING A RIGHT HAND CLOSING DOOR



The items shown in this frame are used in conjunction with the side panel for fixing to the wall, when a left side panel (viewed from outside) is required. For a right side panel application use the right wall profile components

